

TNC 700



Low Profile Load Cell **Series TNC 700**

Capacities 10kN to 1000kN



- ▶ **Stainless or Alloy Steel**
- ▶ **Temperature Compensated**
- ▶ **Rationalised Output**
- ▶ **Bi-directional Calibration**
- ▶ **High Accuracy**
- ▶ **Fatigue Rating**
- ▶ **Sealed to IP67**

 **TNC** *ELECTRONICS Ltd*
STRAIN MEASUREMENT TECHNOLOGY

Creating a pathway to your solution

TNC 700

Technical Data

Standard load ranges	kN	10,25,50,100,200,500,1000
Full load output	mV/V	2.0 (+/-0.25%)
Excitation voltage (recommended) dc or ac	V	10
Excitation voltage (maximum) dc or ac	V	20
Safe service load	%	150
Ultimate load	%	300
Combined error (non linearity and hysteresis)	%	+/- 0.08
Repeatability	%	+/- 0.02
Creep after 30 minutes (at 20 degrees C)	%	+/- 0.03
Output at zero load	%	<+/- 2.0
Input resistance	Ω	780 +/- 30
Output resistance	Ω	700 +/- 5
Operational temperature range	$^{\circ}\text{C}$	- 20 to + 80
Compensated temperature range	$^{\circ}\text{C}$	- 10 to + 40
Temperature coefficient of zero	%/ $^{\circ}\text{C}$	+/- 0.003
Temperature coefficient of span	%/ $^{\circ}\text{C}$	+/- 0.003
Environmental protection		IP 67
Insulation	G Ω	>2 at 100V dc
Construction	stainless steel	

Note: All percentages related to Full Rated Load

Electrical Connections

Via 6 way square flanged fixed Amphenol connector type 62GB-12E10-6P. Supplied with mating half and protective cap.

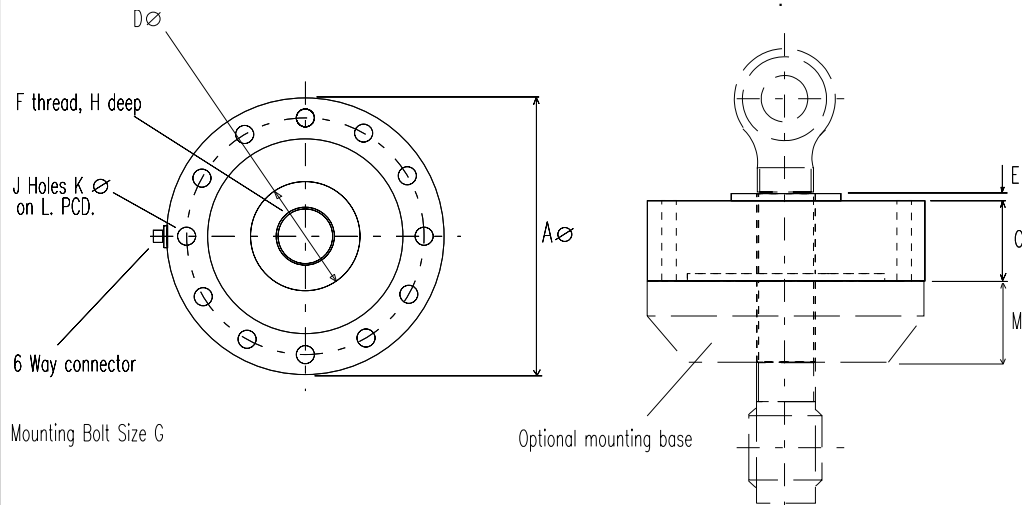

Capacity kN	A	C	D	E	F Thread	G	H	J	K	L PCD	M
10, 25, 50	107	33	33	2	M20 x 2.5P	8	30	8	8.5	90	30
100 & 200	155	44.5	60	3.5	M36 x 2P	10	44	12	11	130	45
500	200	60	80	5	M56 x 4P	16	60	12	17	170	65
1000	275	78	105	12	M72 x 6P	16	85	16	17	235	90

All Dimensions in mm.

TNC's policy is one of continuous development and these specifications are subject to change without notice.



STRAIN MEASUREMENT TECHNOLOGY

Creating a pathway to your solution

Unit C3 Acre Business Park, Acre Road, Berkshire RG2 0SA.

Telephone: 0118 9314107 Facsimile: 01189 9314971

www.tncelectronics.co.uk email: sales@tncelectronics.co.uk